



**Oil -Gas**

**OH2**

**Chemical process pump**

**Model**

**FS-ZE50-3315**

**((4-PO6 A/B))**

**SR. NO. FS-ZE 19811024**

EBARA pumps Europe S.P.A  
SEDE LEGALE  
38023 CLES (TN)- italy -via Campo Sportivo ,30 Telefono +39 0463 660411  
PART. IVA IT 01234660221  
R.E.A.N. 124581 TRENTO

SEDE LEGALE  
38023 CLES (TN)- italy -via Campo Sportivo ,30 Telefono +39 0463 660411  
PART. IVA IT 01234660221  
R.E.A.N. 124581 TRENTO

SEDE OPERATIVA E COMMERCIAIE  
36053 CABELLARA(VI)- Italy -Via Torri di Confine 2/1int. c Telefono  
:+390444706811  
E-mail: ebarapums.epe@ebaracom  
PEC: amministrazione@pec.ebaraeurope.com

Contact to  
Galiano Palatella  
Export Sales Manger  
+393356423310



Oil -Gas

## 4- P06 A/B

Requested flow rate	48.96 m <sup>3</sup> /h
Requested developed head	105.5 m
Pumped medium	kerosene
Temperature	194.44 ° C
Fluid density	634.29 kg/m <sup>3</sup>
Fluid viscosity (cP)	0.35
Vapour pressure	2.51 kg/cm <sup>2</sup> a
Suction pressure max.	1.477 kg/cm <sup>2</sup> g
Efficiency	45.00%
Power Absorbed	30
Pump speed of rotation	2900rpm
NPSH required	2m
Discharge press.	4.43 kg/cm <sup>2</sup> . g
Stuffing box press.	VTA
Shutoff head	121m
Shutoff pressure	8kg/cm <sup>2</sup>
Differential pressure	2.95 kg/cm <sup>2</sup>
NPSH available	14.68 m
Ratio Q/Q <sub>bep</sub>	90.00%
Max. power on curve	28KW
low for continuous stab	VTA
Suction Flange Size & Rating	DN100 5MPa
Discharge Flange Size & Rating	DN50 5MPa
Shaft seal	As Per API 682
Shaft seal manufacture	EBARA
Sealing plan	API plan 23+61 (VTC)
Bearing bracket size	No. 3 bearing box
Coupling Manufacturer	EBARA
Coupling type	Diaphragm coupling
Spacer length	140mm
Driver type	Electric Motor
Drive standard mech.	3-phase Electric Motor
Motor const. type	IBM-200L1-2-30
Motor speed	2985
Frequency	50 Hz
Rated voltage	380
Rated power P2	30KW
Type of protection	EEx de IIB T4 Gb
Motor enclosure	IP55
Volute casing (102)	Cast Steel
Casing cover (161)	Cast Steel
Shaft (210)	2Cr13
Impeller (230)	Cast Steel

EBARA pumps Europe S.P.A



User Name :	
Device Name :	
4-P06 A/B	Quantity : 1
Equipment Name: Chemical Process Pumps	Pump Manufacturer : Ebara oil-Gas
Pump Model:FS-ZE50-3315	

Working Conditions		Material(s)	
Flow rate: 48.96	m3/h	Pump body: Cast steel	Impeller: Cast steel
Inlet gauge pressure: (rated/maximum)	MPa. G	Shaft: 2Cr13	
Outlet gauge pressure:	MPa. G	Mechanical seal flushing plan: PLAN23+61	
Lift(H,m) 105.5 m	(NPSH) a : 14.68 m	Bearing: SKF	Brand: SKF
Usage : <input checked="" type="checkbox"/> Continuous <input type="checkbox"/> intermittent (Number of starts/per day)		Coupling: 140	

Medium

Name: kerosene	
Working temperature:194.44°C	
Medium density:634.291kg/m3	
Viscosity (CP): 0.35	
H2S (Hydrogen Sulfide) Concentration (PPM)	Medium Characteristics: <input type="checkbox"/> Corrosive <input type="checkbox"/> Abrasive <input type="checkbox"/> Toxic

Pump performance and structure

Pump speed of rotation:2985rpm	Efficiency: 45 %	Shaft power: 21kW
Impeller diameter (rated): 300mm	Impeller diameter (maximum): 450 mm	
Impeller diameter (minimum): 280 mm		
MCSF:30m3/h	NPSH: 2m	
Maximum head at rated diameter: 112 m		
From rated head to shutoff head: 90%	Head ratio (rated/maximum): 95%	

Flow rate (Best Efficiency Point, BEP): 515m <sup>3</sup> /h					Flow ratio (rated/BEP): 97 %		
Installation form: <input type="checkbox"/> Vertical <input checked="" type="checkbox"/> Horizontal							
Impeller form: <input checked="" type="checkbox"/> Closed <input type="checkbox"/> Open <input checked="" type="checkbox"/> Semi-open							
Pump Casing Split: Axial <input checked="" type="checkbox"/> Radial							
Pump casing type: <input checked="" type="checkbox"/> Single volute <input type="checkbox"/> Double volute <input type="checkbox"/> Guide casing (guide vane)							
Flange standard: GB9111.1-2000	cali ber mm	Flange pressure rating	Sealing Face Type	Orientat ion position	Electric Motor		
					Model: <input checked="" type="checkbox"/>	IBM-200L1-2-30	
Suction port	100	5MPa	RF	Horizont al	Explosion-Proof High-Voltage Motor		
Discharge port	50	5MPa	RF	Vertical	Rated power: 30kW	Maximum power:	
Drain port	/	/	/	/	Number of Poles: 2	Speed2985 rpm	Frequency: 50 Hz
Pump casing design pressure: 5 MPa		Pump Casing Hydrostatic Test: 7.5 MPa		Voltage: 380 V		Number of phases : 3 PH	Frequency: 50 Hz
Maximum working pressure: 1.2MP		Maximum permissible suction pressure:3.2MPa Maximum permissible working pressure: 5MPa		Protection Rating: IP55		Explosion proof grade: BT4	Insulation grade: F
Bearing type: <input type="checkbox"/> Sliding bearing <input checked="" type="checkbox"/> Radial rolling				Incoming line of junction box:		Method:	Number:
Bearing Lubrication: <input checked="" type="checkbox"/> Oil Bath/Grease <input checked="" type="checkbox"/> Oil Slinger							



# Oil - Gas

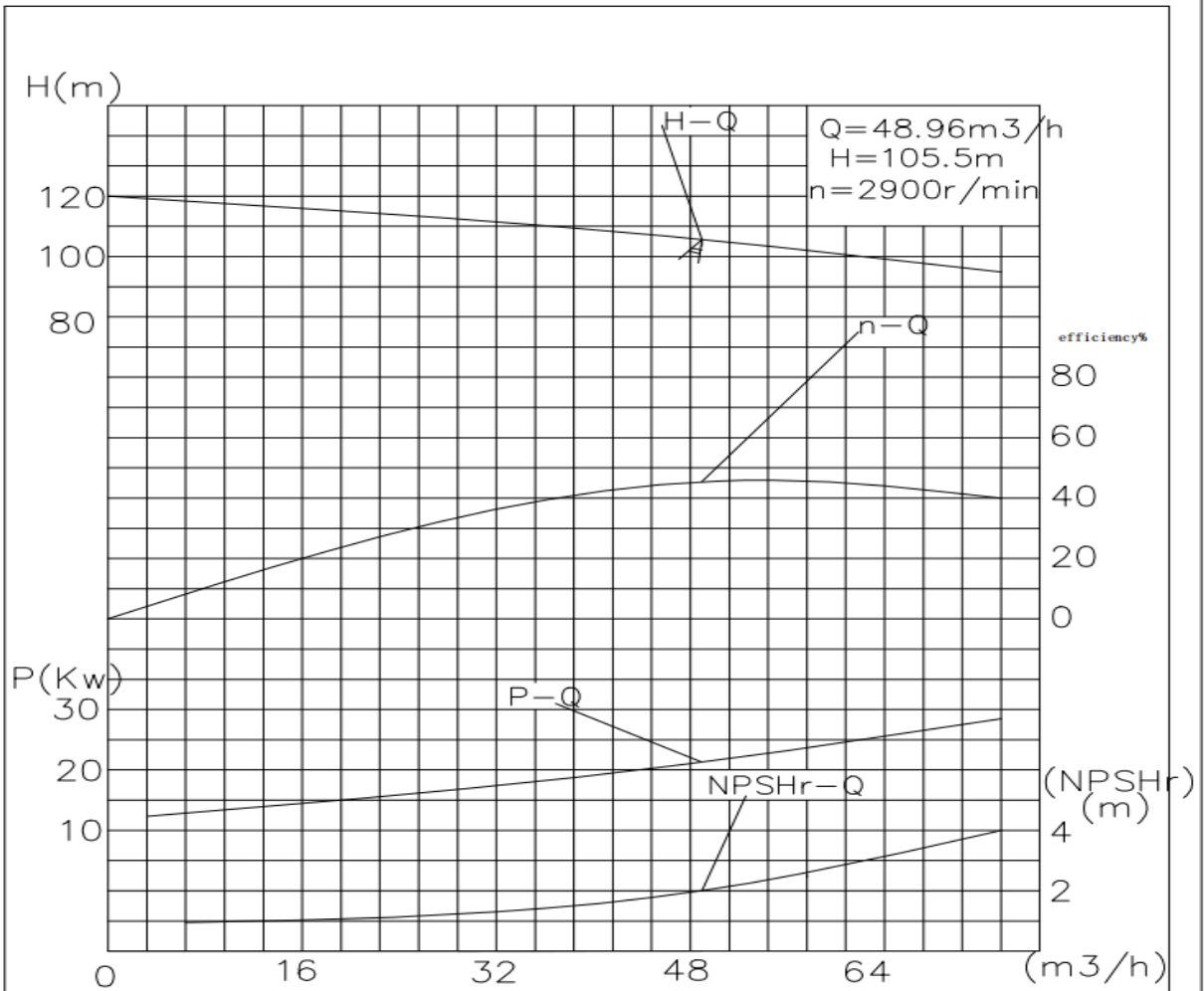

4-P06A/B	(OH <sub>2</sub> ) Chemical Process Pump	FS-ZE50-3315	48.96	105.5	2	API610 standard production, mechanical seal meets API682 standard, material: cast steel, cartridge mechanical seal, mechanical seal flushing solution PLAN 23+61 ( ) SKF bearing, supply scope pump head + base + diaphragm coupling,
	Explosion -proof motor	IBM-200L1-2-30	30KW	2950r/min	2	<small>           *Drive standard machine: three-phase motor            Motor model: IBM-200L1-2-30            Motor speed: 2950            Frequency: 50 Hz            Rated voltage: 380V            Rated power: 30KW            Protection level: Ex de IIB T3            Motor protection level: IP55         </small>

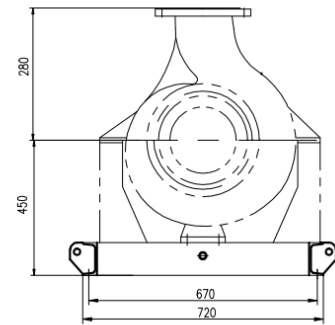
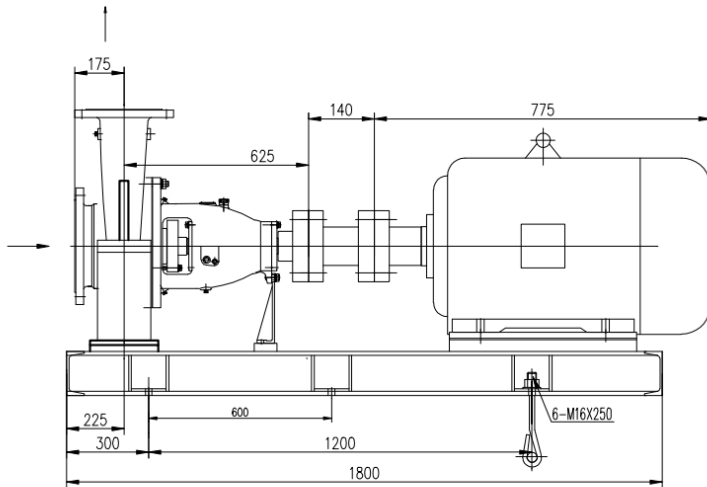

Imported flange

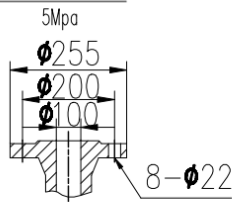

Outlet flange

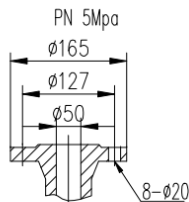

4-P06A/B	(OH2) Chemical Process Pump	FS-ZE50-3315	48.96	105.5	2	API610 standard production, mechanical seal meets API682 standard, material: cast steel, cartridge mechanical seal, mechanical seal flushing solution PLAN 23+61 ( ) SKF bearing, supply scope pump head + base + diaphragm coupling.
	Explosion -proof motor	IBM-200L1-2-30	30KW	2950r/min	2	Drive standard machine: three-phase motor Motor model: IBM-200L1-2-30 Motor speed: 2950 Frequency: 50 Hz Rated voltage: 380V Rated power: 30KW Protection level: Ex de IIB T3 Motor protection level: IP55