



**Oil -Gas**

**OH2**  
**Chemical process pump**  
**Model**  
**FS-ZE40-4400**  
**((100-P27 A/B))**  
**SR. NO. FS-ZE 19811013**

EBARA pumps Europe S.P.A  
SEDE LEGALE  
38023 CLES (TN)- italy -via Campo Sportivo ,30 Telefono +39 0463 660411  
PART. IVA IT 01234660221  
R.E.A.N. 124581 TRENTO

SEDE LEGALE  
38023 CLES (TN)- italy -via Campo Sportivo ,30 Telefono +39 0463 660411  
PART. IVA IT 01234660221  
R.E.A.N. 124581 TRENTO

SEDE OPERATIVA E COMMERCIAIE  
36053 CAMBELLARA(VI)- Italy -Via Torri di Confine 2/1int. c Telefono  
:+390444706811  
E-mail: ebarapums.epe@ebaracom  
PEC: amministrazione@pec.ebaraeurope.com

Contact to  
Galiano Palatella  
Export Sales Manger  
+393356423310



## Oil -Gas

100-P27 A/B	
Requested flow rate	2.27 m <sup>3</sup> /h
Requested developed head	156.52 m
Pumped medium	propane
Temperature	45.99 °C
Fluid density	459.9 kg/m <sup>3</sup>
Fluid viscosity (cP)	0.08
Vapour pressure	15.83 kg/cm <sup>2</sup> a
Suction pressure max.	14.8 kg/cm <sup>2</sup> g
Efficiency	15.00%
Power Absorbed	22
Pump speed of rotation	2900rpm
NPSH required	1m
Discharge press.	20.36 kg/cm <sup>2</sup> .g
Stuffing box press.	VTA
Shutoff head	180m
Shutoff pressure	24kg/cm <sup>2</sup>
Differential pressure	5.56 kg/cm <sup>2</sup>
NPSH available	2.56 m
Ratio Q/Q <sub>bep</sub>	91.00%
Max. power on curve	10KW
low for continuous stab	VTA
Suction Flange Size & Rating	DN50 5MPa
Discharge Flange Size & Rating	DN25 5MPa
Shaft seal	As Per API 682
Shaft seal manufacture	EBARA
Sealing plan	API plan 02+53B (VTC)
Bearing bracket size	No. 3 bearing box
Coupling Manufacturer	EBARA
Coupling type	Diaphragm coupling
Spacer length	140mm
Driver type	Electric Motor
Drive standard mech.	3-phase Electric Motor
Motor const. type	IBM-180M-2-22
Motor speed	2985
Frequency	50 Hz
Rated voltage	380V
Rated power P2	22KW
Type of protection	EEx de IIB T4
Motor enclosure	IP55
Volute casing (102)	Cast Steel
Casing cover (161)	Cast Steel
Shaft (210)	2Cr13
Impeller (230)	Cast Steel

**EBARA pumps Europe S.P.A**



User Name :	
Device Name :	
100-P27 A/B	Quantity : 1
Equipment Name: Chemical Process Pumps	Pump Manufacturer : Ebara oil-Gas
Pump Model:FS-ZE40-4400	

Working Conditions		Material(s)	
Flow rate: 2.27	m3/h	Pump body: Cast steel	Impeller: Cast steel
Inlet gauge pressure: (rated/maximum)	MPa. G	Shaft: 2Cr13	
Outlet gauge pressure:	MPa. G	Mechanical seal flushing plan: PLAN11	
Lift (H, m) 156.52 m	(NPSH) a : 2.56 m	Bearing: SKF	Brand: SKF
Usage : <input checked="" type="checkbox"/> Continuous <input type="checkbox"/> intermittent (Number of starts/per day)		Coupling: 140	
Medium			
Name: propane			
Working temperature: 45.99 °C			
Medium density: 459.9 kg/m3			
Viscosity (CP): 0.08			
H2S (Hydrogen Sulfide) Concentration (PPM)		Medium Characteristics: <input type="checkbox"/> Corrosive <input type="checkbox"/> Abrasive <input type="checkbox"/> Toxic	
Pump performance and structure			
Pump speed of rotation:2985rpm	Efficiency: 15 %	Shaft power: 15kW	
Impeller diameter (rated): 350mm		Impeller diameter (maximum): 400 mm	
Impeller diameter (minimum): 300 mm			
MCSF: 1 m3/h		NPSHr: 1 m	
Maximum head at rated diameter: 165m			
From rated head to shutoff head: 94%		Head ratio (rated/maximum): 96%	
Flow rate (Best Efficiency Point, BEP): 3.5 m3/h		Flow ratio (rated/BEP): 85 %	

Installation form: <input type="checkbox"/> Vertical <input checked="" type="checkbox"/> Horizontal							
Impeller form: <input checked="" type="checkbox"/> Closed <input type="checkbox"/> Open <input checked="" type="checkbox"/> Semi-open							
Pump Casing Split: Axial <input checked="" type="checkbox"/> Radial							
Pump casing type: <input checked="" type="checkbox"/> Single volute <input type="checkbox"/> Double volute <input type="checkbox"/> Guide casing (guide vane)							
Flange standard: GB9111.1-2000	cali ber mm	Flange pressure rating	Sealing Face Type	Orientat ion position	Electric Motor		
					Model: <input checked="" type="checkbox"/>	IBM-280S-2-22	
Suction port	80	5MPa	RF	Horizont al	Explosion-Proof High-Voltage Motor		
Discharge port	40	5MPa	RF	Vertical	Rated power: 22kW	Maximum power:	
Drain port	/	/	/	/	Number of Poles: 2	Speed2985 rpm	Frequency: 50 Hz
Pump casing design pressure: 5 MPa		Pump Casing Hydrostatic Test: 7.5 MPa			Voltage: 380 V	Number of phases : 3 PH	Frequency: 50 Hz
Maximum working pressure: 1.7MP		Maximum permissible suction pressure:3.3MPa Maximum permissible working pressure: 5MPa			Protection Rating: IP55	Explosion proof grade: BT4	Insulation grade: F
Bearing type: <input type="checkbox"/> Sliding bearing <input checked="" type="checkbox"/> Radial rolling					Incoming line of junction box:	Method:	Number:
Bearing Lubrication: <input checked="" type="checkbox"/> Oil Bath/Grease <input checked="" type="checkbox"/> Oil Slinger							



# Oil - Gas

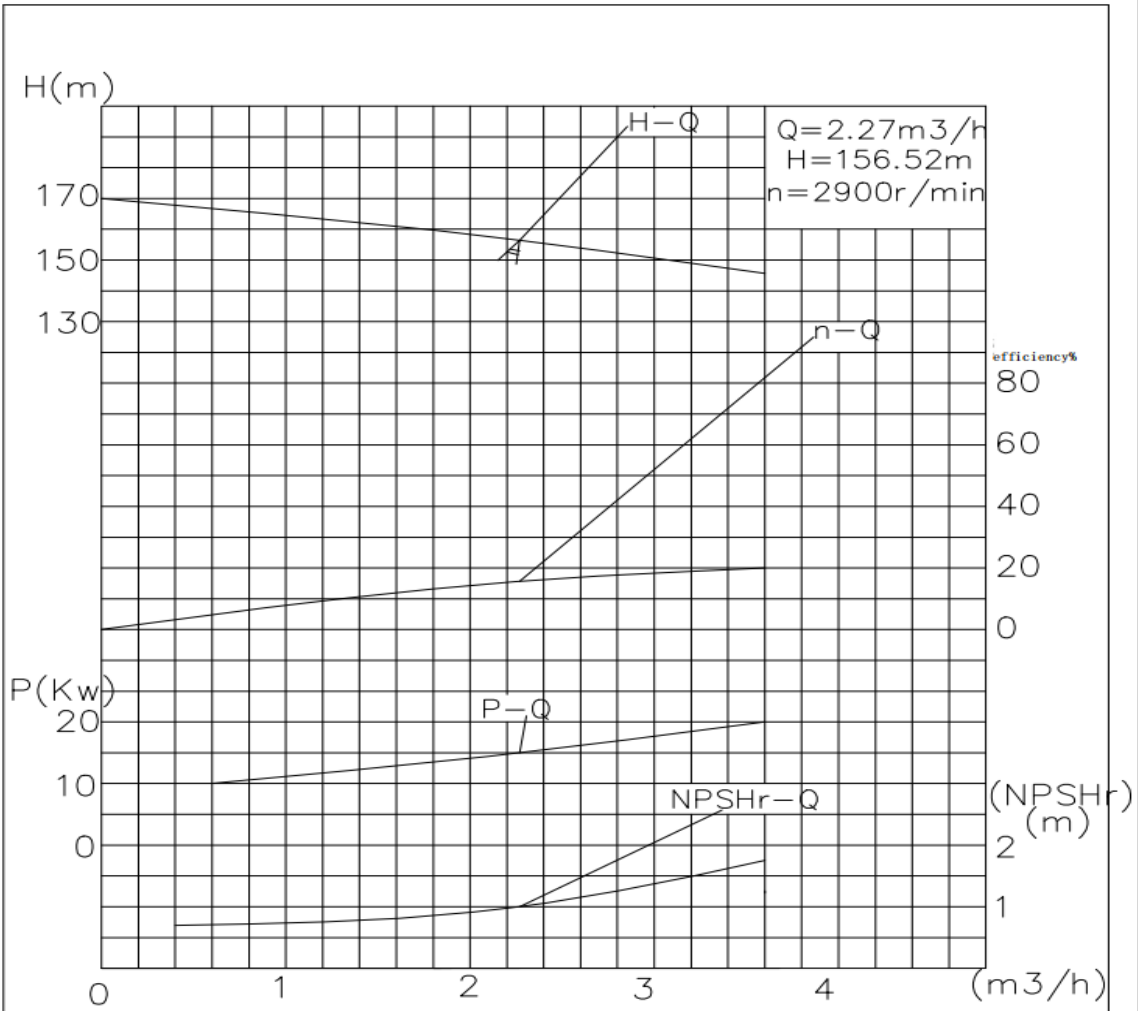

100-P27 A/B	(OH2) Chemical Process Pump	FS_ZE40-4400	2.27	156.52	2	API610 standard production, mechanical seal meets API682 standard, material: cast steel, cartridge mechanical seal, mechanical seal flushing plan PLAN 02+53B ( ) SKF bearings, supply scope pump head + base + diaphragm coupling,
	Explosion -proof motor	IBM-280S-2-22	22KW	2985r/min	2	*Drive standard machine: three-phase motor Motor model: IBM-280S-2-22 Motor speed: 2985 Frequency: 50 Hz Rated voltage: 380V Rated power: 22KW Protection level: Ex de IIB T4 Motor protection level: IP55

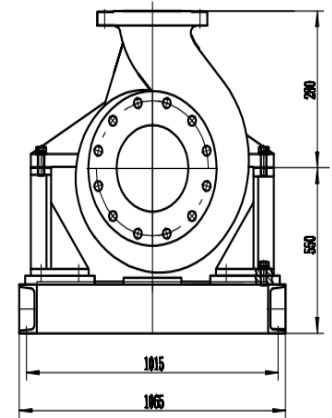
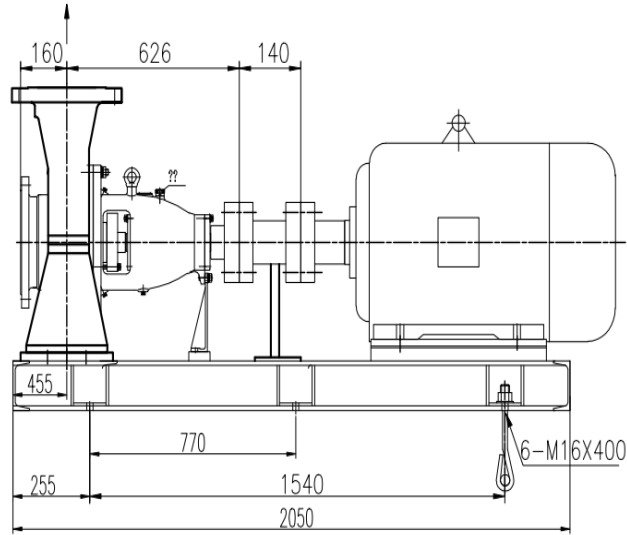

Imported flange

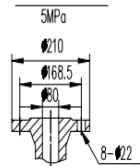

Outlet flange

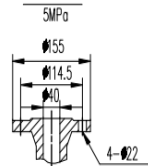

100-P27 A/B	(OH2) Chemical Process Pump	FS_ZE40-4400	2.27	156.52	2	API610 standard production, mechanical seal meets API682 standard, material: cast steel, cartridge mechanical seal, mechanical seal flushing plan PLAN 02+53B ( ) SKF bearings, supply scope pump head + base + diaphragm coupling.
	Explosion -proof motor	IBM-280S-2-22	22KW	2985r/min	2	Drive standard machine: three-phase motor Motor model: IBM-280S-2-22 Motor speed: 2985 Frequency: 50 Hz Rated voltage: 380V Rated power: 22KW Protection level: Ex d IIB T4 Motor protection level: IP55