



Oil -Gas

OH2

Chemical process pump

Model

FS-ZE150-4400

4-P09 A

SR. NO.FS-ZE 19811000

EBARA pumps Europe S.P.A
SEDE LEGALE
38023 CLES (TN)- italy -via Campo Sportivo ,30 Telefono +39 0463 660411
PART. IVA IT 01234660221
R.E.A.N. 124581 TRENTO

SEDE LEGALE
38023 CLES (TN)- italy -via Campo Sportivo ,30 Telefono +39 0463 660411
PART. IVA IT 01234660221
R.E.A.N. 124581 TRENTO

SEDE OPERATIVA E COMMERCIAIE
36053 CAMBELLARA(VI)- Italy -Via Torri di Confine 2/1int. c Telefono
:+390444706811
E-mail: ebarapumps.epe@ebaracom
PEC: amministrazione@pec.ebaraeurope.com

Contact to
Galiano Palatella
Export Sales Manger
+393356423310



User Name :	
Device Name :	
4-P09A	Quantity : 1
Equipment Name: Chemical Process Pumps	Pump Manufacturer : Ebara oil-Gas
Pump Model:FS-ZE150-4400	

Working Conditions		Material(s)	
Flow rate: 312.69	m ³ /h	Pump body: Cast steel	Impeller: Cast steel
Inlet gauge pressure: (rated/maximum)	MPa.G	Shaft: 2Cr13	
Outlet gauge pressure:	MPa.G	Mechanical seal flushing plan: PLAN23+53B	
Lift(H,m) 213.25 m	(NPSH)a : 4.76 m	Bearing: SKF	Brand: SKF
Usage : <input checked="" type="checkbox"/> Continuous <input type="checkbox"/> intermittent(Number of starts/per day)		Coupling: 250	
Medium			
Name: light gas oil			
Working temperature:348.01°C			
Medium density:834.64kg/m ³			
Viscosity (CP): 4.7			
H ₂ S (Hydrogen Sulfide) Concentration (PPM)		Medium Characteristics: <input type="checkbox"/> Corrosive <input type="checkbox"/> Abrasive <input type="checkbox"/> Toxic	
Pump performance and structure			
Pump speed of rotation:2985rpm	Efficiency: 70 %	Shaft power: 220kW	
Impeller diameter (rated): 380mm		Impeller diameter (maximum): 400 mm	
Impeller diameter (minimum): 350 mm			

MCSF:150m ³ /h NPSH: 6m							
Maximum head at rated diameter: 235m							
From rated head to shutoff head: 93%				Head ratio (rated/maximum): 97%			
Flow rate (Best Efficiency Point, BEP): 330m ³ /h				Flow ratio (rated/BEP): 87 %			
Installation form: <input type="checkbox"/> Vertical <input checked="" type="checkbox"/> Horizontal							
Impeller form: <input checked="" type="checkbox"/> Closed <input type="checkbox"/> Open <input type="checkbox"/> Semi-open							
Pump Casing Split: Axial <input checked="" type="checkbox"/> Radial							
Pump casing type: <input checked="" type="checkbox"/> Single volute <input type="checkbox"/> Double volute <input type="checkbox"/> Guide casing (guide vane)							
Flange standard: GB9111.1-2000	caliber mm	Flange pressure rating	Sealing Face Type	Orientation position	Electric Motor		
					Model: <input checked="" type="checkbox"/>	IBM-400-2-280	
Suction port	150	5MPa	PF	Horizontal	Explosion-Proof High-Voltage Motor		
Discharge port	150	5MPa	PF	Vertical	Rated power: 280kW	Maximum power:	
Drain port	/	/	/	/	Number of Poles: 2	Speed2985 rpm	Frequency: 50 Hz
Pump casing design pressure: 5 MPa		Pump Casing Hydrostatic Test: 7.5 MPa		Voltage: 3300 V		Number of phases : 3 PH	Frequency: 50 Hz
Maximum working pressure: 2.4MPa		Maximum permissible suction pressure:2.6MPa Maximum permissible working pressure: 5MPa		Protection Rating: IP55		Explosion proof grade: BT4	Insulation grade: F
Bearing type: <input type="checkbox"/> Sliding bearing <input checked="" type="checkbox"/> Radial rolling				Incoming line of junction box:		Method:	Number:
Bearing Lubrication: <input checked="" type="checkbox"/> Oil Bath/Grease <input checked="" type="checkbox"/> Oil Slinger							



Oil - Gas

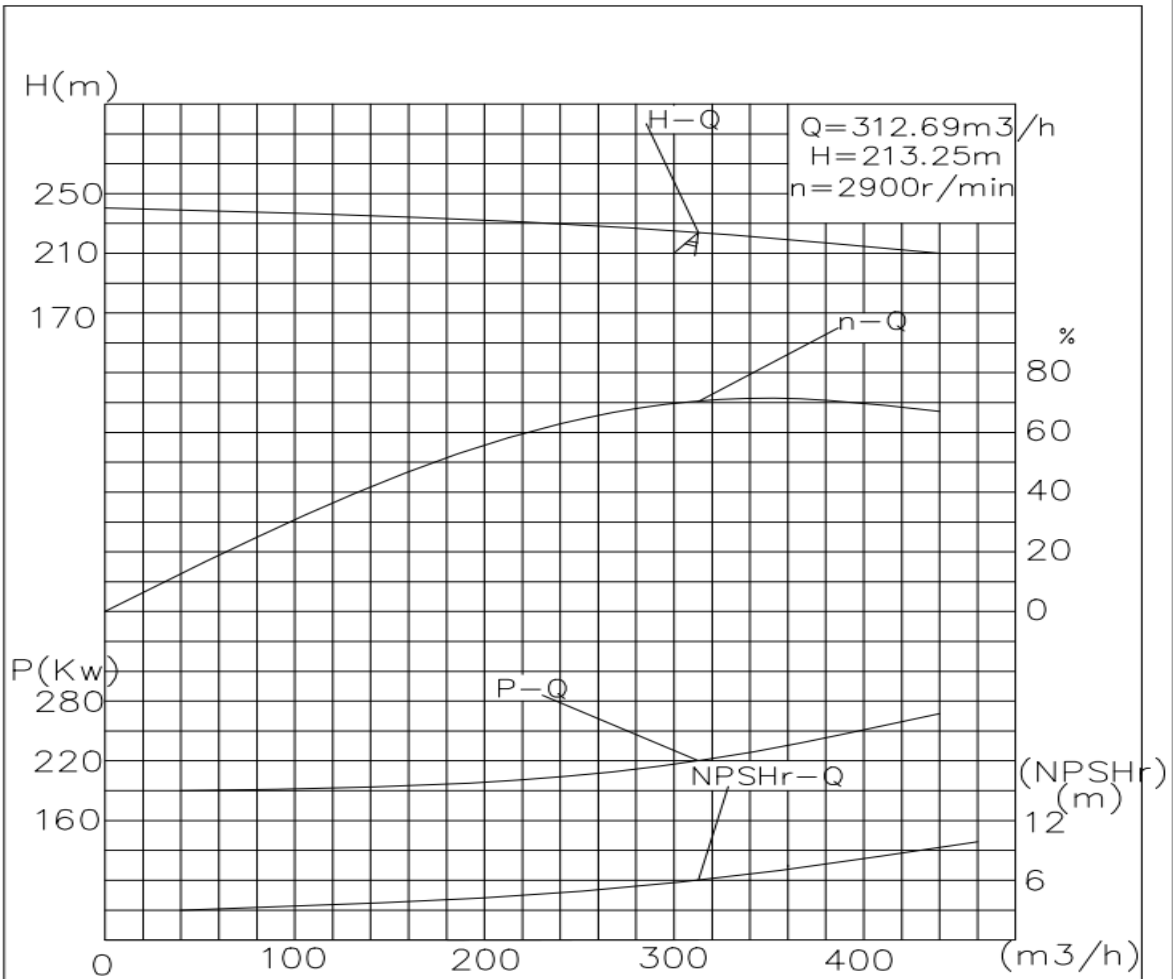

Line Item	name	model	flow: Q (m3/h)	Lift (H, m)	Quantity	Remark
4-P09 A	(OH2) Chemical Process Pump	PS-ZE150-4400	312.69	213.25	1	API610 standard production, mechanical seal meets API682 standard, material: cast steel, cartridge mechanical seal, mechanical seal flushing solution PLAN 23+53B () SKF bearings, supply scope pump head + base + diaphragm coupling.
	Explosion-proof motor	IBM-400-2-280	280KW	2980r/min	1	Drive standard machine: three-phase motor Motor model: IBM-400-2-280 Motor speed: 2980 Frequency: 50 Hz Rated voltage: 3300V Rated power: 280KW Protection level: Ex de IIB T4 Motor protection level: IP55



Oil -Gas

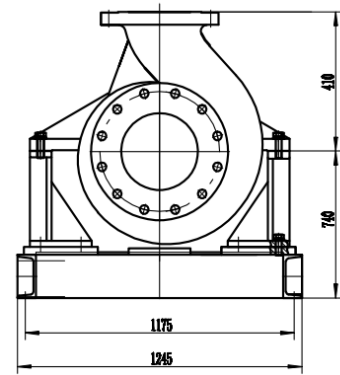
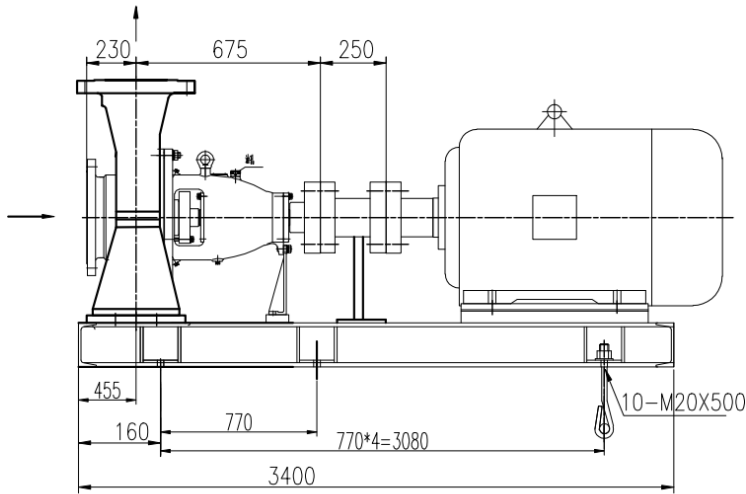

Imported flange
PN 5Mpa

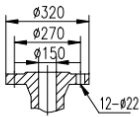

Outlet flange
PN 5Mpa

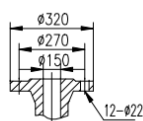

Line Item	name	model	flow: Q (m ³ /h)	Lift (H, m)	Quantity	Remark
4-P09 A	(OH2) Chemical Process Pump	PS-ZE150-4400	312.69	213.25	1	API610 standard production, mechanical seal meets API682 standard, material: cast steel, cartridge mechanical seal, mechanical seal flushing solution PLAN 23+53B () SKF bearings, supply scope pump head + base + diaphragm coupling.
	Explosion-proof motor	IBM-400-2-280	280KW	2980r/min	1	Drive standard machine: three-phase motor Motor model: IBM-400-2-280 Motor speed: 2980 Frequency: 50 Hz Rated voltage: 3300V Rated power: 280KW Protection level: Ex de IIB T4 Motor protection level: IP55



Oil -Gas

Requested flow rate	312.69 m ³ /h
Requested developed head	213.25 m
Pumped medium	Atm Residue
Temperature	348.01 °C
Fluid density	834.64 kg/m ³
Fluid viscosity (cP)	4.7
Vapors pressure	2.57 kg/cm ² a
Suction pressure max.	1.537 kg/cm ² g
Efficiency	70.00%
Power Absorbed	280
Pump speed of rotation	2900rpm
NPSH required	6m
Discharge press.	7.14 bar.g
Stuffing box press.	VTA
Shutoff head	245m
Shutoff pressure	20kg/cm ²
Differential pressure	5.6 bar
NPSH available	4.76 m
Ratio Q/Qbep	94.00%
Max. power on curve	275KW
low for continuous stab	VTA
Suction Flange Size & Rating	DN150 5MPa
Discharge Flange Size & Rating	DN150 5MPa
Shaft seal	As Per API 682
Shaft seal manufacture	EBARA
Sealing plan	API plan 23 (VTC)
Bearing bracket size	No. 4 bearing box
Coupling Manufacturer	EBARA
Coupling type	Diaphragm coupling
Spacer length	250mm
Driver type	Electric Motor
Drive standard mech.	3-phase Electric Motor
Motor const. type	IBM-4005-2-280
Motor speed	2985
Frequency	50 Hz

Rated voltage	3300
Rated power P2	280KW
Type of protection	EEx de IIB T4
Motor enclosure	IP55
Volute casing (102)	Cast Steel
Casing cover (161)	Cast Steel
Shaft (210)	2Cr13
Impeller (230)	Cast Steel